

⚠ Discontinued as of August 31, 2012

Panasonic
ideas for life

**TOGGLE SWITCHES WITH
HIGH INRUSH RESISTANCE**

**AJ4 (J4) TOGGLE
SWITCHES**

12 dia.

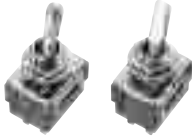

RoHS Directive compatibility information
<http://www.nais-e.com/>

FEATURES

1. Excellent anti-inrush properties allow it to handle large inrush currents.

With a wedge mechanism that increases contact efficiency by $\sqrt{2}$ times and through use of an oxide Ag alloy for superior anti-weld properties, this compact switch is capable of high-capacity switching.

This makes it ideal for circuits with high inrush currents such as those in motor load and lamp load.

2. High level of safety with at least 3 mm between contacts.

Compliant with overseas safety standards.

(ON-OFF and ON-ON type)

Insulation distance between recharge part and ground is at least 6 mm and between poles it is at least 3 mm.

Compliant with the Electrical Appliance and Material Control Law and EN (Class 1) standard.

3. Structure prevents flux from flowing in.

A sealant used around the terminals completely prevents flux from flowing in.

4. Fire retardant molding material used in body.

Excels in anti-arcing (180 s) and anti-tracking (600 V) through use of UL94V-0 fire retardant electric-use molding material.

CONSTRUCTION

- Wedge mechanism <Flat lever type>

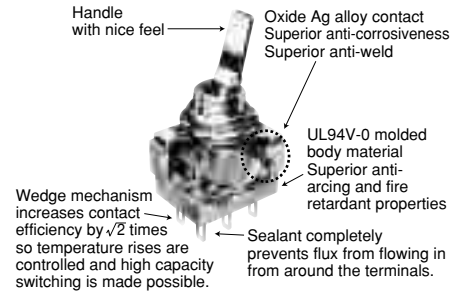

PRECAUTIONS WHEN USING CADMIUM-FREE CONTACT TYPE

Models with cadmium-free contacts have been introduced in order to reduce environmentally harmful substances. ("F" is affixed to the end of the part number.)

We ask customers who are currently using products with cadmium-containing contacts (no "F" at the end of the part number) to please make the switch to models with cadmium-free contacts.

When switching, operating life may differ depending on the load. Please be sure to verify this by conducting an evaluation using actual equipment.

ORDERING INFORMATION

AJ 4 [] [] [] [] F

4: AJ4 type toggle switch

Number of poles and shape of terminal:

- 1: 1-pole, Solder terminal
- 2: 2-pole, Solder terminal
- 4: 4-pole, Solder terminal
- 5: 1-pole, .110 Quick-connect terminal
- 6: 2-pole, .110 Quick-connect terminal
- 8: 4-pole, .110 Quick-connect terminal

Shape of handle:

- 1: Standard toggle
- 3: Flat lever

Kind of operation:

- 0: ON-OFF
- 1: ON-ON
- 2: ON-OFF-ON
- 3: ON-OFF-<ON>
- 4: <ON>-OFF-<ON>
- 5: ON-OFF-<ON>

Shape of nut:

- 0: Hexagonal nut

F: Cadmium-free product

PRODUCT TYPES

1. Standard toggle



Number of poles	Kind of operation < >: Momentary position	Solder terminal	.110 Quick-connect terminal
		Part No.	Part No.
1-pole	ON-OFF	AJ41100F	AJ45100F
	ON-ON	AJ41110F	AJ45110F
	ON-OFF-ON	AJ41120F	AJ45120F
	ON-<ON>	AJ41130F	AJ45130F
	<ON>-OFF-<ON>	AJ41140F	AJ45140F
	ON-OFF-<ON>	AJ41150F	AJ45150F
2-pole	ON-OFF	AJ42100F	AJ46100F
	ON-ON	AJ42110F	AJ46110F
	ON-OFF-ON	AJ42120F	AJ46120F
	ON-<ON>	AJ42130F	AJ46130F
	<ON>-OFF-<ON>	AJ42140F	AJ46140F
	ON-OFF-<ON>	AJ42150F	AJ46150F
4-pole	ON-OFF	AJ44100F	AJ48100F
	ON-ON	AJ44110F	AJ48110F
	ON-OFF-ON	AJ44120F	AJ48120F
	ON-<ON>	AJ44130F	AJ48130F
	<ON>-OFF-<ON>	AJ44140F	AJ48140F
	ON-OFF-<ON>	AJ44150F	AJ48150F

Remark: Standard installation accessories are included with the product.

2. Flat lever



Number of poles	Kind of operation < >: Momentary position	Solder terminal	.110 Quick-connect terminal
		Part No.	Part No.
1-pole	ON-OFF	AJ41300F	AJ45300F
	ON-ON	AJ41310F	AJ45310F
	ON-OFF-ON	AJ41320F	AJ45320F
	ON-<ON>	AJ41330F	AJ45330F
	<ON>-OFF-<ON>	AJ41340F	AJ45340F
	ON-OFF-<ON>	AJ41350F	AJ45350F
2-pole	ON-OFF	AJ42300F	AJ46300F
	ON-ON	AJ42310F	AJ46310F
	ON-OFF-ON	AJ42320F	AJ46320F
	ON-<ON>	AJ42330F	AJ46330F
	<ON>-OFF-<ON>	AJ42340F	AJ46340F
	ON-OFF-<ON>	AJ42350F	AJ46350F
4-pole	ON-OFF	AJ44300F	AJ48300F
	ON-ON	AJ44310F	AJ48310F
	ON-OFF-ON	AJ44320F	AJ48320F
	ON-<ON>	AJ44330F	AJ48330F
	<ON>-OFF-<ON>	AJ44340F	AJ48340F
	ON-OFF-<ON>	AJ44350F	AJ48350F

Remark: Standard installation accessories are included with the product.

3. Accessories

1) Installation accessories (Repair parts)

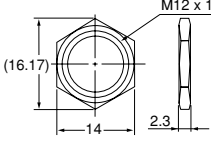
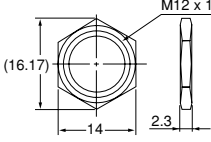
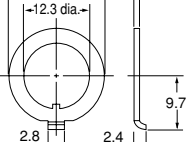
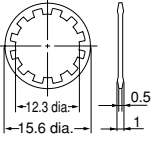
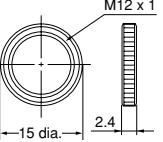
Product name	Standard installation accessories				Optional installation accessories
	Front hex nut (Nickel plated)	Back hex nut (Uni-chrome plated)	Keying washer	Lock washer	Front Knurl nut (Nickel plated)
Dimensions (mm)					
Part No.	AJ3081	AJ3082	AJ3083	AJ3084	AJ3080

Remark: A selling unit of each accessory is 10 pieces.

2) Accessories (Option)

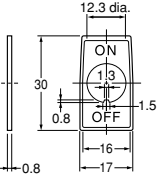
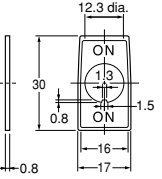
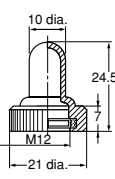
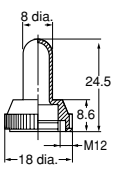
Product name	Indication plate (aluminum)*3		Rubber cap*1, 2, 4	
	ON-OFF	ON-ON	EP rubber type	Silicone rubber type
Dimensions (mm)				
Part No.	WD1901	WD1902	WD1911	WD1811*

Remarks: 1. The asterisk in the part number WD1811* for the silicon rubber type rubber cap is where the letter representing the color should be inserted.

(Standard models: B: black; R: red; Z: grey. Made to order: Y: yellow; G: green.)

2. Rubber and EP rubber caps are only available in black.

3. Letters on the display panel are aluminum colored and the area surrounding the letters is black.

4. Rubber caps are compatible with the J4 switch, T-15 series switch, T-10 series switch, and T-03/T-06 series switches (when plate thickness is 2.7 mm or less).

SPECIFICATIONS

1. Contact rating

Kind of load	AJ4 type					Electrical life
	ON-OFF ON-ON		Electrical life	ON-OFF-ON ON-<ON> <ON>-OFF-<OFF> ON-OFF-<ON>		
	1-pole and 2-pole	4-pole		1-pole and 2-pole	4-pole	
Resistive load	10A 125V AC 10A 250V AC 10A 30V DC	6A 250V AC 6A 30V DC	Min. 3×10 ⁴	10A 125V AC 10A 250V AC 10A 30V DC	6A 250V AC 6A 30V DC	Min. 3×10 ⁴
Inductive load (pf = 0.6)	10A 250V AC	6A 250V AC	Min. 3×10 ⁴	10A 250V AC	6A 250V AC	Min. 3×10 ⁴
Lamp load (incandescent)	300W 100V AC	200W 100V AC	Min. 3×10 ⁴	300W 100V AC 200W 100V AC	200W 100V AC 100W 100V AC	Min. 10 ⁴ Min. 3×10 ⁴
Motor load (single phase)	200W 125V AC 400W 250V AC	50W 125V AC 100W 250V AC	Min. 3×10 ⁴	200W 125V AC 400W 250V AC 100W 125V AC 200W 250V AC	— 50W 125V AC 100W 250V AC	Min. 10 ⁴ Min. 3×10 ⁴

Remark: The rating displayed on the product is 10 A, 250 V AC only.

AJ4

2. Characteristics

Mechanical life	Min. 10 ⁵ (20 cpm)
Electrical life	See above. (10 cpm)
Insulation distance	Between grounds: Min. 6 mm, Between poles: Min. 3 mm, Between contacts: Min. 3 mm (ON-OFF and ON-ON type only)
Insulation resistance	Min. 100 MΩ (at 500 V DC measured by insulation resistive meter)
Breakdown voltage	ON-OFF and ON-ON type: 2000 Vrms, Other types: 1500 Vrms (at detection current: 10mA)
Contact resistance	Initial, Max. 10 mΩ (By voltage drop at 1 A, 2 to 4 V DC)
Vibration resistance	10 to 55 Hz at double amplitude of 1.5 mm (contact opening Max. 10μs)
Shock resistance	Min. 490 m/s ² (contact opening Max. 10μs)
Actuator strength (static load)	112.7N for 1 min.
Terminal strength (static load)	24.5N for 1 min.
Ambient temperature	-25°C to +85°C (Not freezing below 0°C)
Contact material	AgZnO alloy

CIRCUIT DIAGRAM

Terminal arrangement (As seen from terminal side)			1-pole	2-pole	4-pole
Handle position and contact terminal number	ON-OFF		2-3	2-3, 5-6	1-3, 4-6, 7-9, 10-12
			—	—	—
	ON-ON ON-<ON>		2-3	2-3, 5-6	2-3, 5-6, 8-9, 11-12
			1-2	1-2, 4-5	1-2, 4-5, 7-8, 10-11
	ON-OFF-<ON> <ON>-OFF-<ON> ON-OFF-<ON>		2-3	2-3, 5-6	2-3, 5-6, 8-9, 11-12
			—	—	—
		1-2	1-2, 4-5	1-2, 4-5, 7-8, 10-11	
Remark			ON-OFF type does not have a terminal No. 1.	ON-OFF type does not have terminal No. 1 and No. 4.	ON-OFF type does not have terminal No. 2, 5, 8 and 11.

Remark: For ON-<ON>, ON-OFF-<ON> type, the lever springs back (momentary position) when pushed toward the keyway side.

MOUNTING DIMENSIONS

Panel cutout (mm)			
Panel thickness	Max. 3.5 mm	Max. 4.0 mm (without keying washer)	Max. 4.0 mm (without keying washer)

Remark: For panel installations, be sure to use the back hex nut.

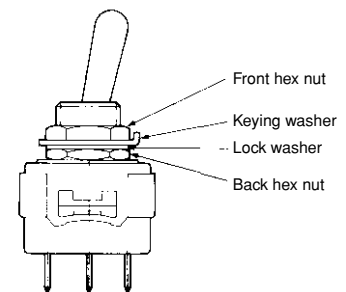

HANDLE SHAPE (mm)

Standard toggle	Flat lever

DIMENSIONS (mm) body and terminal shape (For standard toggle) (General tolerance: ± 0.5)

1. Solder terminal

1-pole type



4-pole type

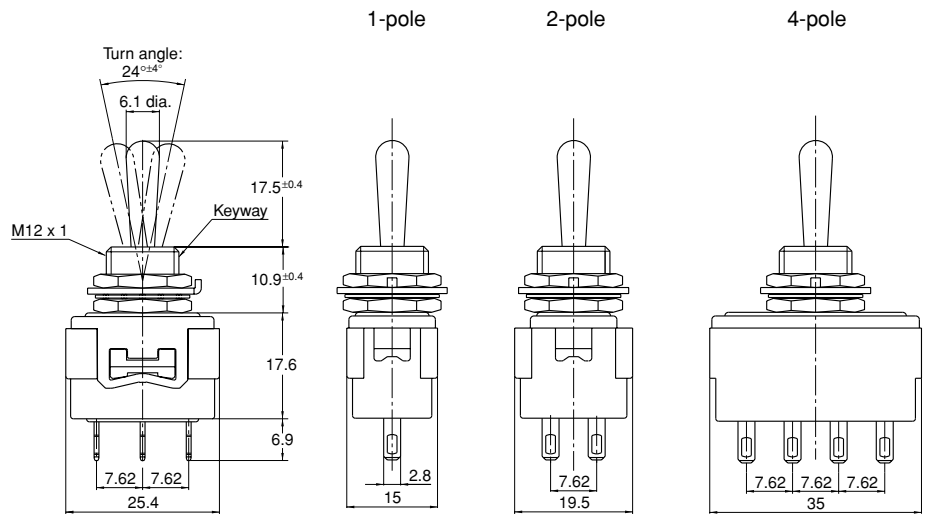

Remarks: For 1-pole, ON-OFF type does not have a terminal No. 1.
 For 2-pole, ON-OFF type does not have terminal No. 1 and No. 4.
 For 4-pole, ON-OFF type does not have terminal No. 1, 4, 7 and 10.

2. .110 Quick-connect terminal

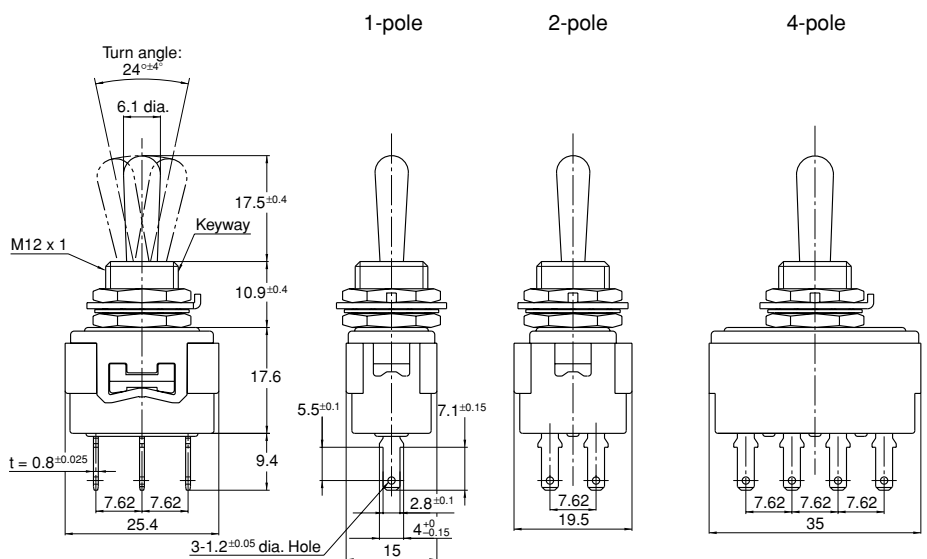

Remarks: For 1-pole, ON-OFF type does not have a terminal No. 1.
 For 2-pole, ON-OFF type does not have terminal No. 1 and No. 4.
 For 4-pole, ON-OFF type does not have terminal No. 1, 4, 7 and 10.

NOTES

1. Installation

Keep the panel tightening torque to less than 1.96 N-cm. Also, do not tighten the nut, holding the switch.

2. For induction load switching

(relays, solenoids and buzzers, etc.) we recommend inserting a suitable spark quenching circuit in order to prevent damage to the contacts due to the possibility of arcing caused by back voltage.

3. For hand soldering, a 350°C soldering iron should be used with the soldering completed within 5 seconds. Also, care should be taken not to touch the body of the switch with the soldering iron.

4. We cannot guarantee performance if the product is dropped onto a hard, concrete floor from a height of 80 cm or more. Please be careful.

5. When using the switch, be careful not to apply unreasonable perpendicular force (static loading of 112.7 N or more) in the operation direction.

6. Verification of insulation distance

Please verify that insulation distances have been maintained between terminals and with ground after installation and wiring of the switch.

When wiring the .110 Quick connect terminal we recommend using a receptacle with an insulating sleeve. Also, after wiring make sure that the terminals are free from any steady forces.

7. This product is not hermetically sealed, so its performance could deteriorate under certain ambient conditions. Avoid using and storing these switches in a location where they will be exposed to corrosive gases, silicon, or high dust levels, all of which can have an adverse effect on the contacts.

8. Do not use the switches where they will come into contact with water through splashing, etc. This could cause abnormal heating and smoke generation, which could damage the circuit and lead to an accident.

9. Do not use in atmospheres that contain combustible gas. Such use could cause fires and explosions.